

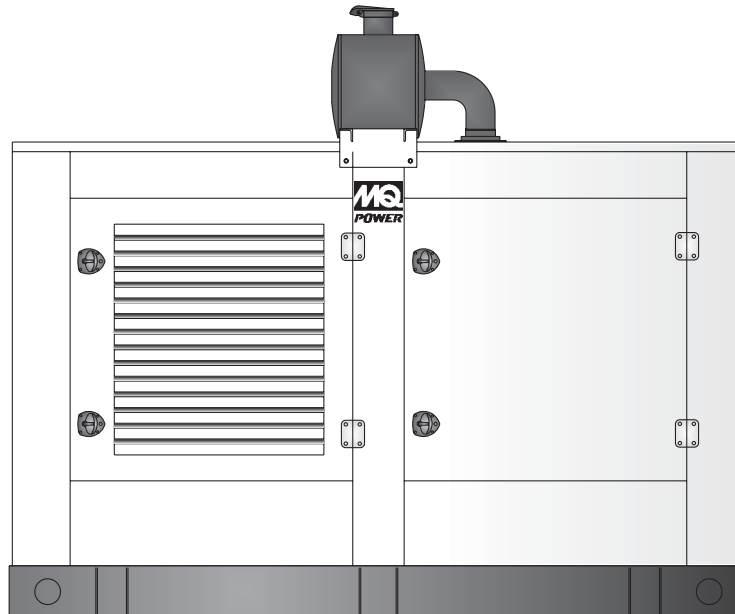

175kW Diesel On-Site Power Industrial Generator

Model	Emissions	Standby Rating	Prime Rating
MQP175IV	EPA Certified	60 Hertz	
		175kW (218.75kVA)	158kW (197.50kVA)



Standard Features

Heavy Duty Engine

- Heavy duty, 4-cycle, diesel engine; direct injection.
- Meets EPA Tier 3 emissions standards.

Alternator

- Brushless, 4-pole, synchronous, 12 lead design.
- Compliant with NEMA MG1-22, BS5000, CSA-C22-2, IEC-34-1 standards for temperature rise.
- Sustained short-circuit capability allowing downstream coordination breakers to trip without collapsing the generator field.
- Drip-proof, self-venting, amortisseur windings.
- Epoxy impregnated windings with tropical insulation for increased environmental protection and long life.
- Exceptional waveshape and voltage balance; 2/3 pitch winding to minimize harmonic distortion.

Electronic Voltage Regulator

- Encapsulated electronic voltage regulator precisely regulates the current into the exciter field.
- Solid-state, voltage regulation of 1% no load to full load.

Full Load Acceptance

- Accepts 100% of standby nameplate rating in one step, in compliance with NFPA, para 5-13.2.6.

Cooling System

- Closed circuit, pressurized system with ambient temperature rating of 40°C (104°F).

Generator Control Panel

- MEC 20™ microprocessor-based, digital control panel; vibration isolated and NFPA110 compliant.
- Liquid crystal display screen with alphanumeric readout for display and programming.
- Self-diagnostic feature continuously verifies processing, memory circuits and input/output.

Skid and Housing

- Generator available as skid-mount or sub-base tank mount design.
- Integral vibration isolators.
- Outdoor weather-protective housing or sound-attenuated housing designs.

Warranty

- Engine-generator sets are covered by an express written 2-year limited warranty.
- Optional extended warranties available.

Agency Approval

- UL 2200 certification.
- CSA standard C22.2 No. 100-04



175kW Diesel On-Site Power Industrial Generator

Alternator Specifications	Standard 3-Phase Generator	Optional Full-Output 1-Phase Generator	Optional 600 VAC 3-Phase Generator
Manufacturer/Model	Marathon Magnaplus 431PSL6204	Marathon Magnaplus 431PSL6226	Marathon Magnaplus 431PSL6242
Type	4-Pole, Rotating Field	4-Pole Rotating Field	4-Pole Rotating Field
Exciter Type	Brushless, Shunt Excitation	Brushless, Shunt Excitation	Brushless, Shunt Excitation
Number of Leads	12 Lead, Broad Range, Reconnectable	4 leads	4 leads
Voltage Regulator	SE350, Solid State, Volts-per-Hz	SE350	SE350
Insulation	NEMA MG1-1.66	NEMA MG1-1.66	NEMA MG1-1.66
Material	Class H	Class H	Class H
Temperature	125°C, Standby Rating	125°C, Standby Rating	125°C, Standby Rating
Bearing, Type	Single, Sealed	Single, Sealed	Single, Sealed
Coupling	Flexible Disk Type	Flexible Disk type	Flexible Disk type
Cooling Air Volume	1100 cfm	1100 cfm	1100 cfm
Amortisseur Windings	Full	Full	Full
Voltage Regulation (no load to full load)	1%	1%	1%
Single Step Load Acceptance per NFPA 110	100% of Rating	100% of Rating	100% of Rating

Engine Specifications	
Manufacturer/Model	Iveco Motors / NEF67 TE2X *
Type	4-cycle, direct injection, turbocharged, charge air cooled, ECM
Cylinder Arrangement	6 in line
Displacement	408 in ³ (6.7 liter)
Bore	4.09 in. (104 mm)
Stroke	5.20 in. (132 mm)
Compression Ratio	16.5 : 1
Cylinder Block	Cast iron
Cylinder Head	Cast iron overhead valves
Brake Mean Effective Pressure (BMEP)	299 psi (2060 kPa)
Rated RPM	1800 rpm
SAE Gross Horsepower	279 hp
Governor Type	Electronic
Frequency Regulation: no load to full load	Isochronous under varying loads from no load to 100% rated load
Frequency Regulation: Steady State	±0.25 of mean value for constant loads from no load to full load
Air Cleaner Type	Dry

* EPA engine model number F4HE9685A

Rating Guidelines

STANDBY POWER: Rating corresponds to ISO Standard Fuel Stop Power. It is applicable for supplying standby electrical power at variable load in areas with well established electrical networks in the event of normal utility power failure. No overload capability is available for this rating.

PRIME POWER: Rating corresponds to ISO Standard Power for continuous operation. It is applicable for supplying electrical power at variable load for an unlimited number of hours instead of commercially purchased power. A 10% overload capability is available for this rating.

SINGLE PHASE OUTPUT: Broad range alternators supply single phase output up to 2/3 set rated 3-phase kW at 1.0 P.F. Refer to Amperage chart.

MQP175IV Rev 3

Amperage			
Voltage	Phase	Wire	Amps
120/208 Volt	3	4	607
120/240 Volt	3	4	526
277/480 Volt	3	4	263
600 VAC	3	4	210
120/240 Volt	1	3	729

Fuel System	
Fuel Injection Pump Make	Stanadyne
Recommended Fuel	ASTM-D975/No.1-D & No.2-D
Fuel Filters	Spin-on, Fuel/Water separator
Maximum Fuel Flow	66 gal/hr (250 L/hr)
Fuel Consumption	
Diesel Fuel At % of Load (Standby)	gal/hr (L/hr)
100%	13.5 (51.0)
80%	10.2 (38.9)
50%	6.4 (24.2)
25%	3.1 (11.7)

Exhaust System	
Exhaust Flow at Rated kW	1388 cfm (39.3 m ³ /min)
Exhaust Temperature at Rated kW	1040°F (560°C)
Maximum Allowable Backpressure	20 in/H ₂ O (5 kPa)
Heat Rejection To Exhaust	9355 Btu/min (164.3 kW)



175kW Diesel On-Site Power Industrial Generator

Lubrication System

Type	Gear Driven
System Capacity - Less Filter	3.1 gal (12 L)
System Capacity - With Filter	4.5 gal (17.2 L)
Oil Filter	Full flow disposable
Oil Pressure At Rated Speed	300-500 kPa
Maximum Oil Temperature	248°F (120°C)

Cooling System

Exhaust Manifold Type	Liquid
Radiator Design	Horizontal Discharge
Ambient Temperature	104°F (40°C)
Coolant Capacity - Engine Only	2.8 gal (10.5 L)
Coolant Capacity - with Radiator	9 gal (33 L)
Water Pump Design/Type	Belt Design, Centrifugal Vane
Coolant Flow	44.6 gal/min (169 L/min)
Radiator Cooling Air	15468 cfm (438 m³/min)
Heat Rejection From Engine	894 Btu/min (15 kW)
Heat Rejection To Coolant	5530 Btu/min (97 kw)
Fan Diameter	27 in. (685 mm)
Fan Horsepower	9.25 hp (6.9 kW)
High Water Temperature Indication	217°F (103°C)
Pressure Cap Setting	10.1 psi (70 kPa)

Engine Electrical System

Battery Charging Alternator - Make	Bosch
Ground Type	Negative
Volts (DC)	14VDC
Ampere Rating	90A
Starter Motor Make/Model	Bosch
Starter Motor Rated Voltage	12VDC
Starter Battery Capacity	1 x 100 Ah

Derating Factors

	Altitude	Ambient Temperature
The engine may be operated up to 1000m altitude and 40°C ambient temperature at the Standby rating, without derating. For operation at higher altitudes and ambient temperatures, the power should be derated according to the following factors:	>3% / 1640 ft.	>1.5% / 5°C

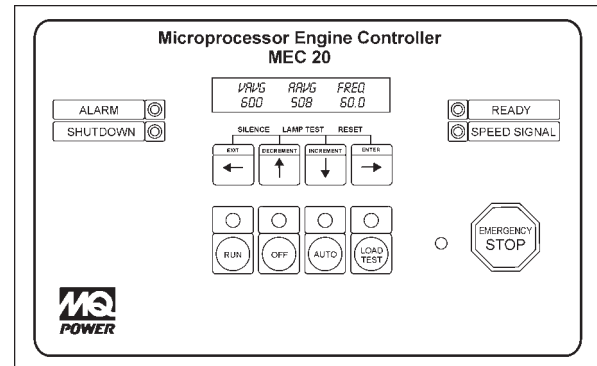

GENERATOR CONTROLLER

- MEC 20™ microprocessor-based digital generator controller.
- 12 or 24 Volt DC compatible.
- Meets all NFPA 110 requirements for emergency power systems Level I installations.
- Backlit LCD display screen with alphanumeric readout.
- Front panel keypad provides password protected programming.
- Self diagnostic features continuously verify processing, input/output and memory circuits.
- Metering accurate to ±1% within temperature range of 0°C to +50°C.
- EMI/RFI noise immunity and surge performance per IEEE C62.41.
- Certified to UL508 and CSA 22.2 #14 Industrial Control Equipment Standards.

Standard Controller Features

AC Metering Display:

- Voltage/Amperage/ Frequency
- Generator Phase Voltage / Current
- Generator Frequency

Engine Information Display:

- Engine Temperature / Oil Pressure (psi)
- Battery Voltage (DC) / Tachometer
- Hourmeter

Minor Fault Warning Display:

- Switch Not In Auto
- Low Fuel Level
- Low Oil Pressure Alarm
- Low Engine Temperature
- High Engine Temperature Alarm
- Low Battery Voltage
- High Battery Voltage
- Weak Battery Condition
- Battery Charger Input Fail
- Undervoltage
- Over / Underfrequency
- Overcurrent

Major Fault Shutdown Display:

- Overvoltage
- Emergency Stop
- Loss Of Speed
- Overcrank
- Overspeed
- Low Oil Pressure
- High Engine Temperature
- Low Coolant Level
- Spare Programmable Digital Faults

Switches And Operating Controls:

- Run / Off / Auto / Load Test Buttons
- Decrement / Increment / Previous (Exit) /Next (Enter) Program Buttons
- Emergency Stop Button
- Audible Alarm Horn – 80 dB(A) at 2 ft.
- Alarm Horn Silence Button
- Lamp Test Button
- Fault Reset Function
- RJ45 Remote Communications, External Expansion Module Ports

Timer Countdown Display:

- Engine Start Delay
- Oil Bypass
- Overcrank
- Cycle Crank
- Starter Re-engage Delay
- Bypass Delay

Control LED Indicators:

- Switch Position (Run,Off,Auto,Test)
- Common Alarm (Minor Fault)
- Common Shutdown (Major Fault)
- Generator Ready (When in Auto)
- Speed Signal
- Emergency Stop

Diagnostic LED Indicators:

- Run Output Energized
- Crank Output Energized
- Remote Start Signal Initiated
- Common Fail Output Energized
- Watchdog - CPU Running
- Programmable Output Contacts



175kW Diesel On-Site Power Industrial Generator

Generator Set Options

Alternator

- Generator Strip Heater
- Permanent Magnet Generator (PMG)

Control Panel

- Remote Monitoring and Generator Network Communications Link
- Voltage Adjusting Rheostat
- Frequency Adjust Potentiometer

Engine

- Engine Crankcase Ventilation Filter (STD)
- Engine Block Heater

Enclosed Unit

- Outdoor Weather-protective Housing
- Outdoor Sound-Attenuated Housing
- Critical Grade Exhaust Silencer
- Exhaust Mounting Package
- Rain Cap

Open Unit

- Critical Exhaust Silencer
- Exhaust Mounting Package

Cooling System

- Coolant Heater
- Low Coolant Shutdown Safety
- Radiator Duct Flange

Electrical System

- Battery
- Environmental Plastic Battery Box with Lid
- Battery Tender® Charger, Float Type, 5 Amperes @ 12VDC / (2.5A@24 VAC)
- Battery Charger, Equalize/Float Type 3.5 Amperes
- Battery Charger w/Alarms, Equalize/Float Type, 10 Amperes

Fuel System

- Sub-base Fuel Tank (12-hr / 200 gal), Double Wall, UL142
- Sub-base Fuel Tank (24-hr / 400 gal), Double Wall, UL142

Miscellaneous

- Main Line Circuit Breaker
 - 120/208 Volt, 3 Phase, 3 Pole
 - 120/240 Volt, 3 Phase, Delta, 3 Pole
 - 139/240 Volt, 3 Phase, 3 Pole
 - 277/480 Volt, 3 Phase, 3 Pole
 - 120/240 Volt, 1 Phase, 2 Pole
- Main Line Circuit Breaker Options
 - Auxiliary Contacts
 - DC Shunt Trip
- Remote Annunciator Panel
- Remote Emergency Stop Kit
- Vibration Isolators, Spring Type
- 5-Year Extended Warranty

Automatic Transfer Switch

- Amperage _____
- No. Poles _____
- Type Enclosure _____
- Options _____

Weights and Dimensions

Housing Options	A	B	C		
			Skid-mount	12hr fuel tank*	24hr fuel tank*
Open Genset	115 in. (2,921 mm)	57 in. (1,448 mm)	62 in. (1,575 mm)	69 in. (1,753 mm)	82 in. (2,083 mm)
	Weight ¹		4,069 lbs (1,847 kg)	4,995 lbs (2,267 kg)	5,494 lbs (2,494 kg)
Standard Housing	115 in. (2,921 mm)	57 in. (1,448 mm)	96.5 in. (2,451 mm)	103.5 in. (2,626 mm)	116.5 in. (2,959 mm)
	Weight ¹		4,669 lbs (2,119 kg)	5,645 lbs (2,562 kg)	6,094 lbs (2,766 kg)
Sound Attenuated Housing	151 in. (3,835 mm)	57 in. (1,448 mm)	96.5 in. (2,451 mm)	103.5 in. (2,626 mm)	116.5 in. (2,959 mm)
	Weight ¹		4,934 lbs (2,240 kg)	5,910 lbs (2,683 kg)	6,359 lbs (2,886 kg)

* Optional

1. Weights are approximate and are based on dry gensets with standard equipment. The total weight may vary according to fluid additions and/or optional equipment ordered with the unit.

Backfeed to a utility system can cause electrocution and/or property damage. Do not connect to any building's electrical system except through an approved device.

Your MQ Power dealer is:

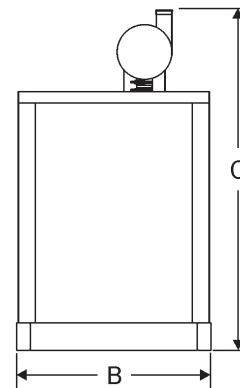
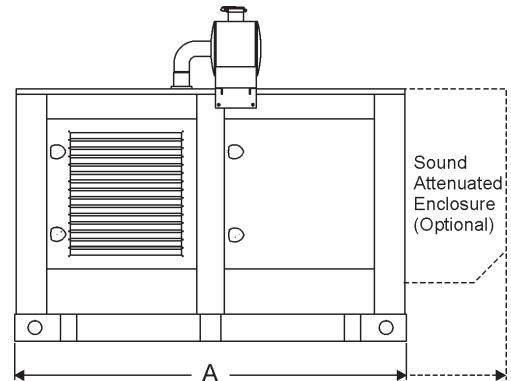

MQ POWER
 POST OFFICE BOX 6254
 CARSON, CA 90749
 310-537-3700 • 800-421-1244
 FAX: 310-632-2656
 E-MAIL: mqpower@multiquip.com
 WEBSITE: www.mqpower.com